

FEDERAL SUPPLY CLASS
5306

RATIONALE

FIGURE REDRAWN TO SHOW CORRECT THREAD END CHAMFER AND LIGHTENING HOLE DIMENSIONS TO AS1132.

REV.
B

AS3150™

SAE Technical Standards Board Rules provide that: " This report is published by SAE to advance the state of technical and engineering sciences. The use of this report is entirely voluntary, and its applicability and suitability for any particular use, including any patent infringement arising therefrom, is the sole responsibility of the user." SAE invites your written comments and suggestions. SAE reviews each technical report at least every five years at which time it may be revised, reaffirmed, stabilized, or cancelled.

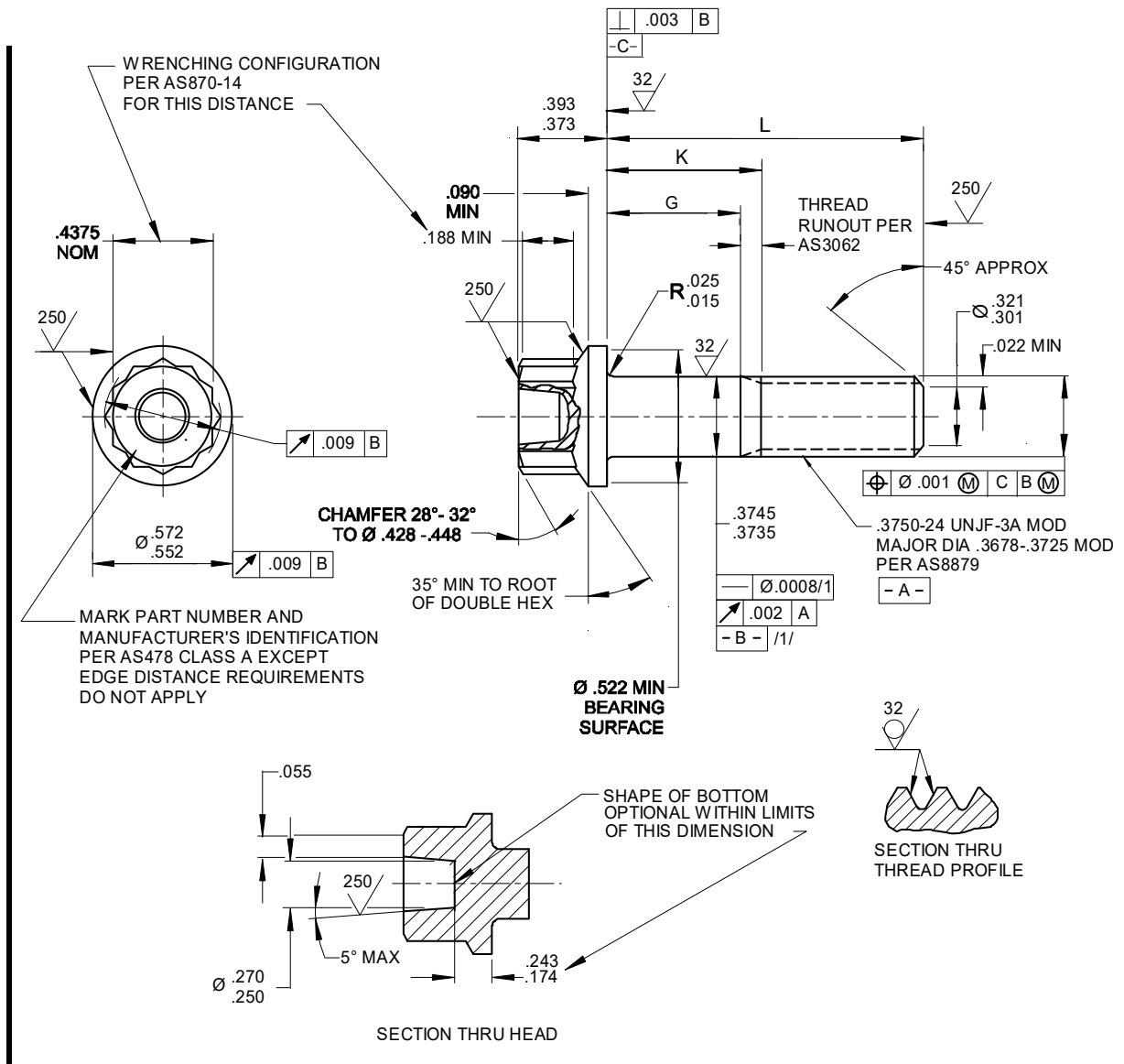
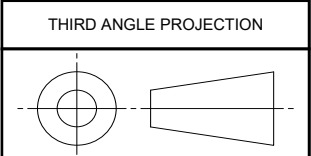

FIGURE 1 - BOLT

SAE values your input. To provide feedback on this Technical Report, please visit <http://standards.sae.org/AS3150B>



CUSTODIAN: E-25

PROCUREMENT SPECIFICATION: AS7461 /8/



AEROSPACE STANDARD

BOLT, MACHINE - DOUBLE HEXAGON EXTENDED WASHER HEAD, CLOSE TOLERANCE SHANK, AMS4967 (UNS R56400), 160 KSI .3750-24 UNJF-3A

AS3150™
SHEET 1 OF 3

REV.
B